



TC-312

OPERATOR'S MANUAL

Issue 1.

Date of issue: 1st August 2003

® The Techne logo is the trademark of
Techne and Techne Inc.

© Techne , 2003



Barloworld Scientific

Contents

TC-312 Operator's Manual

<i>Safety and Installation</i>	<i>page</i>
Declaration of conformity	3
English	4
Français	5
Deutsch	6
Español	7
<i>The TC-312</i>	8
Warning	8
Unpacking	8
Typical Specification	9
Uses of the TC-312	10
Heated lid	11
Tubes or reaction vessel	11
Tubes	12
Cleaning your TC-312	12
<i>Front panel controls</i>	14
Display	14
Indicators	14
The keys	15
<i>Before switing on</i>	16
Switching on	16
Symbols on the screen	16
<i>Programming the TC-312</i>	17
Glossary	17
Some frequently asked questions	18
Notes on transferring protocols from slower machines	19
Programming the TC-312	19
Programming options	19
<i>Creating programs, option 1, using templates</i>	20
To give a new program a name	21
To save a program	21
<i>Creating "new" programs, option 2</i>	22
To add a loop and then edit it	22
To insert additional segments	23
To give a new program a name	24
To save a program	24
<i>Further programming</i>	25
To edit,copy or delete an existing program	25
To delete a segment	26
To add a loop before an existing one	27
To add a loop at the end	27
To delete a loop	27
To insert a 'pause' into a program	28
To program increment or decrement temperature or time	29
To save a program	31
<i>To run a program</i>	32
Manual pause	33
Manual stop	33
Program Information	33
<i>Additional information</i>	34
Running the TC-312 from a PC	35
Other information on the web-site	35
Connecting one unit to a computer	37
Connecting several units to a computer	37
Interchangeable blocks	38
Accessories	38
Replacement parts	38

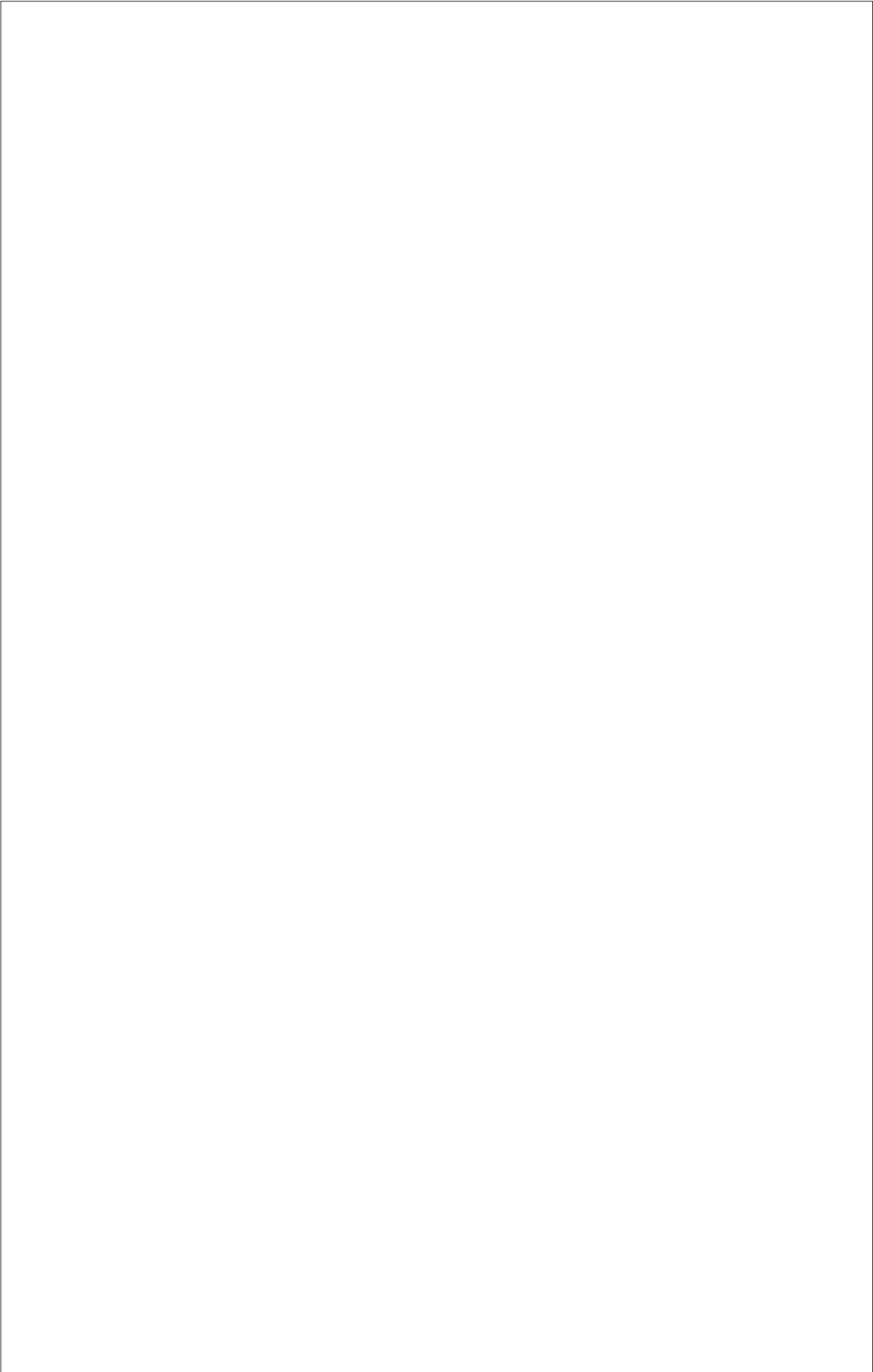



Techne
Duxford
Cambridge
CB2 4PZ



Declaration of Conformity

Techne Unit TC-312 has been designed to comply with the following European Standards:

EN 61326:1998 Electrical equipment for measurement, control and laboratory use.
EMC requirements.

EN 61010-1:1993 Safety requirements for electrical equipment for
measurement, control and laboratory use.

EN 61010-2-010:1995 Particular requirements for laboratory equipment for the
heating of materials.

I have made all reasonable enquiries regarding the unit stated and its
conformance to the following EU directives:

Low Voltage directive, 73/23/EEC and amendment 93/68/EEC, and
EMC Directive 89/336/EEC and amendment 92/31/EEC.

To the best of my knowledge and belief these units conform to these directives.

This Declaration is controlled under an ISO 9001:2000 system certificated by
BSI Quality Assurance, certificate number FM13585.

Signature

Name

B C Coombes

Position

Quality Manager

Issue 1

01/08/2003

Introduction

Please read all the information in this booklet before using the unit.

Warning

HIGH TEMPERATURES ARE DANGEROUS: they can cause serious burns to operators and ignite combustible material.

Techne have taken great care in the design of these units to protect operators from hazards, but users should pay attention to the following points:

- USE CARE AND WEAR PROTECTIVE GLOVES TO PROTECT HANDS;
- DO NOT put hot objects on or near combustible objects;
- DO NOT operate the unit close to inflammable liquids or gases;
- DO NOT place any liquid directly in your unit;
- At all times USE COMMON SENSE.

Operator Safety

All users of Techne equipment must have available the relevant literature needed to ensure their safety.

It is important that only suitably trained personnel operate this equipment, in accordance with the instructions contained in this manual and with general safety standards and procedures. If the equipment is used in a manner not specified by Techne the protection provided by the equipment to the user may be impaired.

All Techne units have been designed to conform to international safety requirements and are fitted with an overtemperature cutout. On some models, the cutout is adjustable and should be set to suit the application. On all other models the cutout is preset to protect the unit.

If a safety problem should be encountered, switch off at the mains socket and remove the plug from the supply.

Installation

1. All Techne units are supplied with a power cable. This may be integral or plug-in.
2. Before connecting the mains supply, check the voltage against the rating plate. Connect the mains cable to a suitable plug according to the table below. **Note that the unit must be earthed to ensure proper electrical safety.**

Connections	220/240V	110/120V
Live	Brown	Black
Neutral	Blue	White
Earth	Green/yellow	Green

The fused plug supplied with the mains lead for use in the UK is fitted with the following value fuse to protect the cable: 230V UK 10 AMP

The fuse in the unit protects the unit and the operator.

Note that units marked 230V on the rating plate work at 220V; units marked 120V work at 110V. In both cases, however, the heating rate will degrade by approximately 8%. The rating plate is on the rear of the unit.

3. Plug the mains cable into the socket on the rear of the unit.
4. Place the unit on a suitable bench or flat workspace, or in a fume cupboard if required, ensuring that the air inlet vents on the underside are free from obstruction.
5. Note that the following symbol next to the indicator lamp on the front panel of the units and has the following meanings:

 : the power indicator

6. Symbols on or near the power switch of the unit have the following meanings:

I : mains switch On
O : mains switch Off

After use

When you have finished heating samples, remember that parts of the unit – the tubes, blocks and associated accessories – may be very hot. Take the precautions listed earlier.

Guarantee

The unit is guaranteed against any defect in material or workmanship for the period specified on the enclosed guarantee card. This period is from the date of purchase, and within this period all defective parts will be replaced free of charge provided that the defect is not the result of misuse, accident or negligence. Servicing under this guarantee should be obtained from the supplier.

Notwithstanding the description and specification(s) of the units contained in the User's Manual, Techne hereby reserves the right to make such changes as it sees fit to the units or to any component of the units.

This Manual has been prepared solely for the convenience of Techne customers and nothing in this Instruction Book shall be taken as a warranty, condition or representation concerning the description, merchantability, fitness for purpose or otherwise of the units or components.

User maintenance

NOTE THAT THIS EQUIPMENT SHOULD ONLY BE DISMANTLED BY PROPERLY TRAINED PERSONNEL. REMOVING THE SIDE, FRONT OR REAR PANELS EXPOSES POTENTIALLY LETHAL MAINS VOLTAGES. THERE ARE NO USER MAINTAINABLE PARTS WITHIN THE EQUIPMENT.

In the unlikely event that you experience any problems with your unit which cannot easily be remedied, you should contact your supplier and return the unit if necessary. Please include any details of the fault observed and remember to return the unit in its original packing. Techne accept no responsibility for damage to units which are not properly packed for shipping: if in doubt, contact your supplier. See the Decontamination Certificate supplied with your unit.

1. Cleaning

Before cleaning your unit ALWAYS disconnect from the power supply and allow to cool below 50° C.

Your unit can be cleaned by wiping with a damp soapy cloth. Care should be exercised to prevent water from running inside the unit. Do not use abrasive cleaners.

2. Fuses

Your unit is protected by one or two fuses. These should only be changed by suitably qualified personnel.

If the fuses blow persistently, a serious fault is indicated and you may need to return the unit to your supplier for repair.

Contact Information

For technical, sales or servicing information, contact your local Techne dealer or,

Techne, Duxford,

Cambridge, CB2 4PZ, United Kingdom.

Telephone: +44(0)1223 832401

Fax: +44(0)1223 836838

Service: +44 (0)1223 836950 Out of office hours

e-mail: sales@techne.com

Web site: www.techne.com

or,

Techne Inc, 3 Terri Lane,

Suite 10, Burlington,

New Jersey 08016, USA.

Telephone: 609-589-2560

Toll free: 800-225-9243 ext 306

Fax: 609-589-2571

e-mail: labproducts@techneusa.com

Web site: www.techneusa.com

Introduction

Veillez lire attentivement toutes les instructions de ce document avant d'utiliser l'appareil.

Avertissement

DANGER DE TEMPERATURES ELEVEES : les opérateurs peuvent subir de graves brûlures et les matériaux combustibles risquent de prendre feu.

Techne a apporté un soin tout particulier à la conception de ces appareils de façon à assurer une protection maximale des opérateurs, mais il est recommandé aux utilisateurs de porter une attention spéciale aux points suivants :

- **PROCEDER AVEC SOIN ET PORTER DES GANTS POUR SE PROTEGER LES MAINS.**
- **NE PAS** poser d'objets chauds sur ou près de matériaux combustibles.
- **NE PAS** utiliser l'appareil à proximité de liquides ou de gaz inflammables.
- **NE PAS** verser de liquide directement dans l'appareil.
- **FAIRE TOUJOURS PREUVE DE BON SENS.**

Sécurité de l'opérateur

Tous les utilisateurs de produits Techne doivent avoir pris connaissance des manuels et instructions nécessaires à la garantie de leur sécurité.

Important : cet appareil doit impérativement être manipulé par un personnel qualifié et utilisé selon les instructions données dans ce document, en accord avec les normes et procédures de sécurité générales. Dans le cas où cet appareil ne serait pas utilisé selon les consignes précisées par Techne, la protection pour l'utilisateur ne serait alors plus garantie.

Tous les appareils Techne sont conçus pour répondre aux normes de sécurité internationales et sont dotés d'un coupe-circuit en cas d'excès de température. Sur certains modèles, ce coupe-circuit est réglable pour s'adapter à l'application désirée. Sur d'autres modèles, il est pré-réglé en usine pour assurer la protection de l'appareil.

Dans le cas d'un problème de sécurité, coupez l'alimentation électrique au niveau de la prise murale et enlevez la prise connectée à l'appareil.

Installation

1. Tous les appareils Techne sont livrés avec un câble d'alimentation qui peut être intégré à l'appareil ou à raccorder.
2. Avant de brancher l'appareil, vérifiez la tension requise indiquée sur la plaque d'identification. Raccordez le câble électrique à la prise appropriée en vous reportant au tableau ci-dessous. **Il est important que l'appareil soit relié à la terre pour assurer la protection électrique requise.**

Connexions	220/240 V	110/120 V
Phase	Marron	Noir
Neutre	Blue	Blanc
Terre	Vert/juane	Vert

Le fusible à l'intérieur de l'appareil est destiné à assurer la protection de l'appareil et de l'opérateur.

Remarque : les appareils dont la plaque indique 230 V peuvent fonctionner sur 220 V, et ceux dont la plaque indique 120 V peuvent fonctionner sur 110 V. Dans les deux cas cependant, la capacité de chauffage diminuera d'environ 8 %. La plaque d'identification se trouve à l'arrière de l'appareil.

3. Raccordez le câble d'alimentation à la prise située à l'arrière de l'appareil.
4. Placez l'appareil sur un plan de travail ou surface plane, ou le cas échéant, dans une hotte d'aspiration, en s'assurant que les trous d'aération situés sous l'appareil ne sont pas obstrués.
5. Les symboles ci-dessous situés à côté des témoins lumineux sur la face avant de l'appareil ont la signification suivante:

 : témoin d'alimentation

6. Les symboles situés sur ou à côté de l'interrupteur de l'appareil ont la signification suivante :

O : arrêt

I : marche

Après utilisation

Lorsque vous avez fini de chauffer les échantillons, n'oubliez pas que certaines parties de l'appareil - les éprouvettes, leurs supports et autres accessoires - risquent d'être très chaudes. Il est donc recommandé de toujours prendre les précautions citées plus haut.

Garantie

L'appareil est garanti contre tout défaut ou vice de fabrication pour la durée figurant sur la carte de garantie, à compter de la date d'achat de l'appareil. Au cours de cette période, toutes les pièces défectueuses seront remplacées gratuitement, dans la mesure où la défaillance n'est pas due à une mauvaise utilisation, un accident ou une négligence. Toute réparation sous garantie sera effectuée par le fournisseur.

Malgré la description et les spécifications de l'appareil données dans le manuel de l'utilisateur, Techne se réserve le droit d'effectuer les changements nécessaires à l'appareil ou à tout élément qui entre dans sa composition.

Ce manuel a été exclusivement rédigé à l'attention des clients de Techne, et aucun élément de ce guide d'instructions ne peut être utilisé comme garantie, condition ou représentation concernant la description, commercialisation, adaptation aux conditions d'utilisation ou autre des appareils ou de leurs composants.

Entretien utilisateur

IMPORTANT : CET APPAREIL NE PEUT ETRE DEMONTE QUE PAR DU PERSONNEL QUALIFIE.

LORSQUE LES PANNEAUX AVANT, ARRIERE ET LATERAUX SONT DEMONTES, L'OPERATEUR EST EXPOSE A DES TENSIONS QUI PEUVENT ETRE MORTELLES.

CET APPAREIL NE CONTIENT AUCUN ELEMENT QUI DEMANDE UN ENTRETIEN DE LA PART DE L'UTILISATEUR.

Dans le cas peu probable où votre appareil présente un défaut de fonctionnement auquel il est difficile de remédier, il est alors préférable de contacter votre fournisseur et, le cas échéant, de renvoyer le matériel. Veuillez inclure une description détaillée du problème constaté et retourner l'appareil dans son emballage d'origine. Techne ne sera pas tenu responsable des dommages subis par tout appareil dont l'emballage est inadéquat pour le transport. Pour plus de sûreté, contactez votre fournisseur. Voir le certificat de décontamination livré avec le produit.

1. Nettoyage

Avant de nettoyer l'appareil, assurez-vous TOUJOURS que le câble d'alimentation est déconnecté et laissez la température redescendre en dessous de 50 °C.

Utilisez un chiffon imprégné d'eau savonneuse pour nettoyer l'appareil. Veillez à ne pas introduire d'eau dans l'appareil. N'utilisez pas de produits abrasifs.

2. Fusibles

La protection de l'appareil est assurée par un ou deux fusibles dont le remplacement ne peut être effectué que par un personnel qualifié.

Si les fusibles sautent sans arrêt, il s'agit d'un problème sérieux. Nous vous conseillons dans ce cas de prendre contact avec votre fournisseur pour réparation.

Einleitung

Bitte lesen Sie diese Bedienungsanleitung komplett bevor Sie dieses Gerät benutzen.

Warnung

HOHE TEMPERATUREN SIND GEFÄHRLICH: sie können dem Bediener ernsthafte Verletzungen zufügen und brennbare Materialien können sich leicht entzünden.

Techne hat bei der Konstruktion dieses Gerätes sehr darauf geachtet, daß der Bediener vor Gefahren geschützt ist. Dennoch sollten Sie auf die folgenden Punkte achten:

- SEIEN SIE VORSICHTIG UND TRAGEN SIE SCHUTZHANDSCHUHE
- Legen Sie heiße Gegenstände NICHT auf oder in die Nähe von leicht brennbaren Materialien; vermeiden Sie Arbeiten in der Nähe von leicht entzündbaren Flüssigkeiten oder Gasen.
- Bringen sie KEINE Flüssigkeiten direkt in Ihr Gerät.
- Benutzen Sie immer den normalen Menschenverstand

Sicherheit des Anwenders

Alle Benutzer von Techne Geräten müssen Zugang zu der entsprechenden Literatur haben, um ihre Sicherheit zu gewähren.

Es ist wichtig, daß diese Geräte nur von entsprechend geschultem Personal betrieben werden, das die in dieser Gebrauchsanweisung enthaltenen Maßnahmen und allgemeine Sicherheitsbestimmungen und -vorkehrungen beachtet. Wenn das Gerät anders eingesetzt wird als vom Hersteller empfohlen, kann dies die persönliche Sicherheit des Anwenders beeinträchtigen. Die Geräte von Techne entsprechen den internationalen Sicherheitsbestimmungen und sind mit einem automatischen Übertemperaturabschalter ausgestattet. Bei einigen Modellen ist der Übertemperaturabschalter verstellbar und sollte je nach Anwendung entsprechend eingestellt werden. Bei allen anderen Modellen ist der Temperaturschutz voreingestellt um Schäden am Gerät zu vermeiden. Wenn ein Sicherheitsproblem auftreten sollte, muß das Gerät ausgeschaltet und vom Stromnetz getrennt werden.

Installation

1. Alle Techne Geräte werden mit einem Stromanschlußkabel geliefert. Dieses ist entweder fest mit dem Gerät verbunden oder zum Einstecken.
2. Vergleichen Sie, ob die Spannung Ihrer Stromversorgung mit den Angaben auf dem Typenschild des Gerätes übereinstimmen. Verbinden Sie das Stromanschlußkabel mit einer geeigneten Stromversorgung gemäß der nächstehenden Tabelle. Achtung: Das Gerät muß geerdet sein, um die elektrische Sicherheit zu gewährleisten!

<i>Verbindungen</i>	<i>220/240V</i>	<i>110/120V</i>
Stromführend	Braun	Schwarz
Neutral	Blau	Weiß
Erde	Grün/Gelb	Grün

Geräte, die für 230 Volt ausgelegt sind, können auch bei 220 Volt arbeiten, Geräte für 120 Volt auch bei 110 Volt. In beiden Fällen verringert sich die Aufheizrate um ca. 8%. Das Typenschild befindet sich hinten am Gerät.

3. Stecken Sie das Stromkabel in die vorgesehene Buchse hinten am Gerät.
4. Stellen Sie das Gerät auf eine ebene Arbeitsfläche bzw. (falls erforderlich) unter einen Laborabzug. Beachten Sie, daß die Entlüftungsrippen an der Geräteunterseite immer frei zugänglich sind.
5. Wenn die Anzeigenlämpchen an der Vorderseite leuchten, hat dies folgende Bedeutung:

~ : Gerät ist eingeschaltet

6. Die Symbole auf oder neben dem EIN/AUS-Schalter an der Geräterückseite bedeuten:

I : An
O : Aus

Nach dem Gebrauch

Vergessen Sie nicht, daß Teile des Gerätes (die Gefäße, die Blöcke und andere Zubehörteile) nach dem Erhitzen von Proben noch sehr heiß sein können. Bitte beachten Sie die oben genannten Vorsichtsmaßnahmen.

Garantie

Die Garantiedauer des Gerätes ist auf der beiliegenden Garantiekarte angegeben und schließt Fehler im Material oder der Verarbeitung ein. Die Garantiedauer beginnt am Tag des Einkaufs. Sämtliche defekte Teile werden innerhalb dieses Zeitraumes kostenlos ersetzt unter der Voraussetzung, daß dem Defekt keine unsachgemäße Handhabung, Fahrlässigkeit oder ein Unfall zugrundeliegt. Der unter diese Garantie fallende Service wird vom Lieferanten geleistet.

Ungeachtet der in dieser Gebrauchsanweisung enthaltenen Beschreibungen und Spezifikationen, behält sich Techne hiermit das Recht vor, Änderungen an den Geräten bzw. an einzelnen Geräteteilen durchzuführen.

Diese Gebrauchsanleitung wurde ausschließlich dazu erstellt, um Kunden die Handhabung der Techne-Geräte zu erleichtern. Nichts in dieser Gebrauchsanleitung darf als Garantie, Bedingung oder Voraussetzung verstanden werden, sei es die Beschreibung, Marktgängigkeit, Zweckdienlichkeit oder sonstiges bezüglich der Geräte oder deren Bestandteile.

Wartung durch den Bediener

BEACHTEN SIE, DASS DIESES GERÄT NUR VON TECHNISCHEN FACHKRÄFTEN GEÖFFNET UND DEMONTIERT WERDEN DARF.

DURCH ENTFERNEN DES GEHÄUSES ODER GEHÄUSETEILEN SIND BAUTEILE MIT LEBENGEFÄHRLICHEN SPANNUNGEN FREI ZUGÄNGLICH.

IM INNERN DES GERÄTES BEFINDEN SICH KEINE TEILE, DIE VOM ANWENDER GEWARTET WERDEN MÜSSEN.

Falls Ihr Gerät nicht ordnungsgemäß arbeitet, wenden Sie sich an Ihren Lieferanten oder senden Sie das Gerät wenn nötig zurück. Fügen Sie eine genaue Beschreibung des Defektes bei. Verpacken Sie das Gerät möglichst im Originalkarton. Bitte beachten Sie, daß Techne keine Haftung bei Transportschäden aufgrund unzureichender Verpackung übernehmen. Setzen Sie sich im Zweifelsfall mit Ihrem Lieferanten in Verbindung. Bitte beachten Sie die Entgiftungsbescheinigung, die Sie mit dem Gerät erhalten haben.

1. Reinigen

Bevor Sie Ihr Gerät reinigen, sollten Sie

- zuerst den Netzstecker ziehen
- das Gerät unter 50°C abkühlen lassen.

Ein feuchtes Tuch mit Seifenlösung reinigt Ihr Gerät am besten. Achten Sie darauf, daß kein Wasser in das Gerät gelangt. Verwenden Sie keine Scheuermittel.

2. Sicherungen

Die Stromzuleitung ist durch ein oder zwei Sicherungen geschützt. Diese sollten nur durch qualifiziertes Fachpersonal ausgetauscht werden. Wenn die Sicherung wiederholt durchbrennt, liegt ein größerer Defekt vor. Das Gerät muß zur Reparatur an Ihren Lieferanten eingeschickt werden.

Introducción

Le rogamos lea cuidadosamente la información contenida en este folleto antes de manipular el aparato.

Aviso

LAS TEMPERATURAS ELEVADAS SON PELIGROSAS: pueden causarle graves quemaduras y provocar fuego en materiales combustibles.

Techne ha puesto gran cuidado en el diseño de estos aparatos para proteger al usuario de cualquier peligro; aún así se deberá prestar atención a los siguientes puntos:

- **EXTREME LAS PRECAUCIONES Y UTILICE GUANTES PARA PROTEGERSE LAS MANOS;**
- **NO** coloque objetos calientes encima o cerca de objetos combustibles;
- **NO** maneje el aparato cerca de líquidos inflamables o gases;
- **NO** introduzca ningún líquido directamente en el aparato;
- **UTILICE EL SENTIDO COMUN** en todo momento.

Seguridad del usuario

Todos los usuarios de equipos Techne deben disponer de la información necesaria para asegurar su seguridad.

De acuerdo con las instrucciones contenidas en este manual y con las normas y procedimientos generales de seguridad, es muy importante que sólo personal debidamente capacitado opere estos aparatos. De no ser así, la protección que el equipo le proporciona al usuario puede verse reducida.

Todos los equipos Techne han sido diseñados para cumplir con los requisitos internacionales de seguridad y traen incorporados un sistema de desconexión en caso de sobretensión. En algunos modelos el sistema de desconexión es variable, lo que le permite elegir la temperatura según sus necesidades. En otros, el sistema de desconexión viene ya ajustado para evitar daños en el equipo.

En caso de que surgiera un problema de seguridad, desconecte el equipo de la red.

Instalación

1. Todos los aparatos Techne se suministran con un cable de alimentación. Puede ser fijo o independiente del aparato.
2. Antes de conectarlo, compruebe que el voltaje corresponde al de la placa indicadora. Conecte el cable de alimentación a un enchufe adecuado según la tabla expuesta a continuación. El equipo debe estar conectado a tierra para garantizar la seguridad eléctrica.

<i>Conexiones</i>	220/240V	110/120V
Linea	Marrón	Negro
Neutro	Azul	Blanco
Tierra	Verde/amarillo	Verde

El enchufe suministrado con el cable de alimentación viene equipado con un fusible del siguiente valor para proteger el cable:

230V Reino Unido 5AMP

El fusible una vez instalado protege tanto al equipo como al usuario.

Asegúrese de que los equipos marcados 230V en la placa indicadora funcionan a 220V y de que los equipos marcados 120V funcionan a 110V. No obstante, en ambos casos la velocidad de calentamiento se verá reducida en un 8% aproximadamente. La placa indicadora está situada en la parte posterior del equipo.

3. Conecte el cable a la toma de tensión en la parte posterior del equipo.
4. Sitúe el aparato en un lugar apropiado tal como una superficie de trabajo plana, o si fuera necesario incluso en una campana con extractor de humos, asegurándose de que las entradas de aire en la parte inferior no queden obstruidas.

5. Los símbolos, que pueden aparecer junto a las luces indicadoras en el panel frontal del equipo, tienen los siguientes significados:

~ : Indicador de potencia

6. Los símbolos que se encuentran en o cerca del interruptor de alimentación tienen los siguientes significados:

I : Interruptor principal encendido

O : Interruptor principal apagado

Después de su uso

Cuando haya finalizado el calentamiento de muestras, recuerde que las piezas del equipo, tales como tubos, bloques y demás accesorios, pueden estar muy calientes. Tome las precauciones mencionadas anteriormente.

Garantía

Este aparato está garantizado contra cualquier defecto material o de fabricación durante el periodo especificado en la tarjeta de garantía adjunta. Este plazo inicia a partir de la fecha de compra, y dentro de este periodo todas las piezas defectuosas serán reemplazadas gratuitamente siempre que el defecto no sea resultado de un uso incorrecto, accidente o negligencia. Mientras se encuentre bajo garantía las revisiones las debe llevar a cabo el proveedor.

A pesar de la descripción y las especificaciones de los aparatos contenidas en el Manual del Usuario, Techne se reserva por medio de este documento el derecho a efectuar los cambios que estime oportunos tanto en los aparatos como en cualquier componente de los mismos.

Este manual ha sido preparado exclusivamente para los clientes de Techne y nada de lo especificado en este folleto de instrucciones se tomará como una garantía, condición o aseveración de la descripción, comerciabilidad o adecuación para cualquier fin específico de los aparatos o sus componentes.

Mantenimiento

ESTE APARATO DEBE SER DESMONTADO SOLO Y EXCLUSIVAMENTE POR PERSONAL DEBIDAMENTE CAPACITADO.

EL RETIRAR LOS PANELES LATERALES, FRONTALES O TRASEROS SUPONE DEJAR AL DESCUBIERTO TENSION DE LA RED PELIGROSA.

EL EQUIPO NO CONSTA DE NINGUNA PIEZA DE CUYO MANTENIMIENTO SE PUEDA ENCARGAR EL USUARIO.

En el caso improbable de que experimentara algún problema con su aparato que no pudiera resolver con facilidad, debería ponerse en contacto con su proveedor y devolverlo si fuera necesario. Indique de forma detallada todos los defectos que haya notado y devuelva el equipo en su embalaje original. Techne no aceptará responsabilidad alguna por daños causados en equipos que no estuvieran debidamente embalados para su envío; si tuviera alguna duda, póngase en contacto con su proveedor. Sírvase consultar el Certificado de Descontaminación suministrado con su aparato.

1. Limpieza

Antes de limpiar su aparato, desconéctelo SIEMPRE de la fuente de alimentación y permita que se enfríe por debajo de los 50°C.

Este aparato se puede limpiar pasándole un paño húmedo enjabonado. Hágalo con cuidado para evitar que caiga agua dentro del mismo. No utilice limpiadores abrasivos.

2. Fusibles

Su aparato está protegido por uno o dos fusibles. Sólo deben cambiarlos personal debidamente capacitado.

Si los fusibles se fundieran repetidamente, esto indicaría una avería grave y puede que tuviera que devolverle el aparato a su proveedor para su reparación.

The TC-312

Before using the TC-312 make sure you have read this manual carefully. If there is any doubt relating to the proper use of this equipment, the staff at Techne or your supplier will be pleased to assist you.

The TC-312 provides the researcher with the means of accurately controlling the temperature profile of samples. It has many scientific applications, including DNA amplification and sequencing. The TC-312 can cycle samples between 4°C and 99°C.

The TC-312 is programmed by means of an integral keypad and LCD display. A program, which can be recalled from memory, consists of:

- a series of specified temperatures in °C
- the times for which each specified temperature will be held (Hold Times)
- the desired heating or cooling rates, in °C/sec, between each specified temperature
- whether the times and/or the temperatures are to increase or decrease when a program is repeated.

The memory can store up to 80 programs.

Warning !

Please note that the keypad on the TC-312 is easily damaged by sharp objects such as pens, pencils and fingernails. Damage of this sort will be considered as misuse and will invalidate the guarantee on this component.

Although the unit is designed to go down to 4°C at this temperature the coolers are working very hard against room temperature. You will prolong the life of the coolers if you can have the hold temperature at the end of a run nearer to ambient, say 15°C.

Position the unit so that the mains on/off switch is accessible. If a safety problem should be encountered, switch off at the mains socket and remove the plug from the supply.

If you are using more than one unit in close proximity to each other, there must be at least 100mm between the units to allow the cooling air to flow from them.

Unpacking

When unpacking the unit, check that the following have been removed from the packing:

- The TC-312 unit
- Mains cable
- Guarantee card
- The TC-312 Operator's Manual
- The TC-312 Reference Card

Make sure you keep the original packing, in case you ever need to return it for service or repair. Techne accepts no responsibility for damage incurred unless the unit is correctly packed and transported in its original packing.

Typical Specification

For a detailed specification please contact Techne Sales

Temperature

Temperature range	4°C to 99°C
Temperature set point precision	0.1°C
Block uniformity (over full range)	± 0.5°C
Temperature accuracy	±0.5°C
End of program cooling below ambient	Yes

Heating/Cooling Rate

Heating rate, between 55°C and 90°C on a 50°C to 95°C segment:

25 x 0.2 ml micro tubes	3.6°C/sec
20 x 0.5ml microcentrifuge tubes	3.6°C/sec

Cooling rate, between 90°C & 55°C on a 95°C to 50°C segment:

25 x 0.2 ml micro tubes	2.0°C/sec
20 x 0.5ml microcentrifuge tubes	1.8°C/sec

Heated Lid

Heated lid enable/disable	Yes
Selectable heated lid temperature	100°C to 115°C
Over-temperature cutout	Fixed at 145°C
Temperature sensor	Thermistor
Heater Type	Etched foil
Heater Power	33W
Warm up time	4 min approximately (ambient to 105°C)

The Heated Lid only comes on if the set temperature is above 35°C

Programming

Program naming using alpha keys	Yes
Program password protection	Yes
Number of programs (3 segment)	80
Maximum number of segments per loop	35
Maximum number of loops per program	25
Minimum hold time	1 sec
Maximum hold time	18 hrs
Incremental/decremental temperature	Yes
Incremental/decremental segment hold time	Yes
Programmable ramp rate (heat or cool) steps	variable in 0.1°C/sec
Programmable ramp rate resolution	0.1°C

Running Programs

Pause button	Yes
Stop button	Yes
End of program alarm	Yes
Auto restart on power fail	Yes

Interconnectivity

Connection to PC control program	Yes
Software updates from Techne web-site	Yes

Dimensions

Height	190mm
Width	170mm
Length	330mm

Serial Port

This socket is provided for RS232 PC link to run "Gensoft".

Power

Power consumption	230W
-------------------	------

The units are voltage selectable by a slide switch. When the unit is set to 115V it will work at any voltage between 110V and 130V. When the unit is set to 230V it will work at any voltage between 198V and 252V.

Units marked 100V will work at any voltage between 90 and 110V.

However, the performance will vary and will not necessarily meet the above typical specification at the extremes of voltage.

Working conditions

The TC-312 is designed to work safely under the following conditions:

Ambient temperature range	5°C to 40°C
Humidity	Up to 95% relative humidity, non-condensing

Note: The control specifications are quoted at an ambient temperature of 20°C. The specification may deteriorate outside an ambient temperature range of 18°C to 30°C.

Radio frequency interference tested and passed to EN50081-1.

Immunity Tested and passed to EN50082-1

Uses of the TC-312

The TC-312 has many scientific laboratory applications, including DNA sequencing and PCR. Aspects of the PCR process are claimed in USA. Patent Nos. 4,683,195, 4,683,202, and 4,965,188. Use of the TC-312 in such processes does not convey a licence to practice the processes themselves.

Heated Lid

To release the heated lid, push gently down on the opening device using the thumb with the palm of the hand over the lid and the catch will release. When you have tubes in the block be careful as the lid will spring open when you press.



Do not shut the lid without tubes being fitted in the block.

Tubes or Reaction Vessel

Techne does not recommend any specific tube or reaction vessel other than those described in this Manual. We recommend using reaction volumes between 20 and 200 μ l. The tubes must withstand a pressure of 1 atmosphere at 100°C. Any vessel must be able to withstand the temperatures you are using without any danger of them deforming to the point where they fracture.

To test your tubes, put 25 μ l of water in each of 5 tubes and subject them to a typical thermal cycling protocol. At the end of the cycle, measure the volume remaining, using a micropipette. A loss of more than 1 or 2 μ l indicates a vapour leak.

The amount of volume loss you observe and the change in reactant concentrations you can tolerate determine the minimum volume that can be used. Typical volume losses of 1 μ l in 30 cycles allow the use of samples of 20 μ l or less.

During the final cool-down, a ring of condensation may form above the liquid level but below the top of the sample block.

Tubes

If you are using the 0.5ml tubes, because of the compact nature of the block, we recommend only flat top, round lidded tubes such as those supplied by Techne. If the tops of the tubes are not flat you may get some condensation.

If the lid is not basically round then you may have trouble fitting the tubes in the block and you may have to fit a smaller number of tubes. Always make sure the Heated Lid is balanced even if you have to put in some dummy tubes.

Even with round lidded tubes, the tubes need to be put in the block so that all the hinges are in the same relative place. An example is illustrated here:

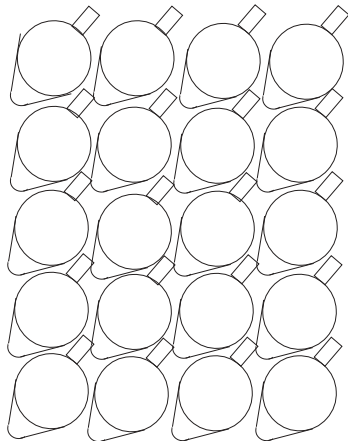

Cleaning your TC-312

Before cleaning your unit, disconnect from the power supply and allow to cool to below 50°C.

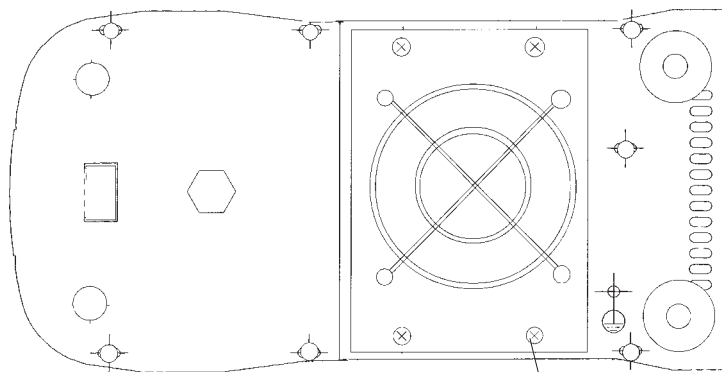

Underside of the TC-312

Four screws which hold the Block/Fan Assembly

The heat/cool block, including wells and flat surfaces, should be cleaned regularly to ensure optimum heat transfer to the samples. Always clean the block if there has been a spillage. Use a cloth or cotton buds dipped in a fresh, 50:50 water/isopropanol solution, and make sure that no deposits are left in the wells.

In the case of radioactive spillages, Techne recommend that you use a proprietary cleaning agent and follow the manufacturer's instructions. The heat/cool block is made of aluminium. Therefore, an agent such as

Neutracon (from Decon Labs Ltd.), suitable for nonferrous metals should be used but remember other parts of the unit are made of ferrous materials and may be damaged by spillage onto them.

You can clean the case of the TC-312 with a cloth dipped in water or ethanol (methanol or formaldehyde can also be used). No part of the case or cover should be immersed in the solvents. Do not use aggressive solvents such as acetone, or abrasive cleaners.

Before using any cleaning or decontamination method except those recommended here, the responsible body should check with Techne that the proposed method will not damage the equipment.

The blocks can be removed for a more detailed cleaning. Remove the four screws beneath the unit and drop the block/fan assembly down. Unplug the assembly from the wiring and remove the assembly from the unit. Refitting the block/fan assembly is the reverse procedure, be careful of the wires as you refit the block.

Front Panel Controls

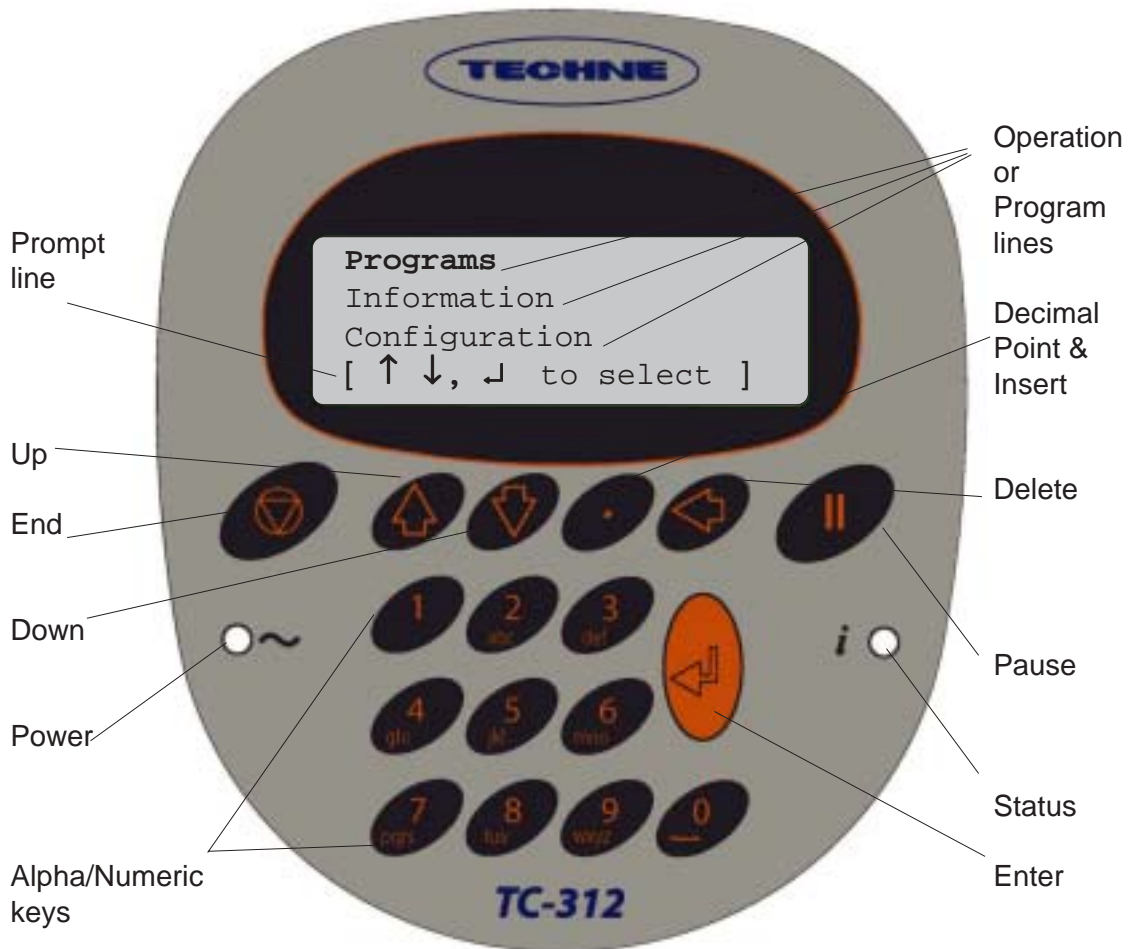

The Display

```

Programs
Information
Configuration
[ ↑ ↓, ↵ to select ]
    
```

The TC-312 has a four line display. The top three lines are information or program lines while the bottom line is a prompt line. The highlighted line flashes on screen but is shown as bold in this manual.

```

-- Loop 1 -----
Number cycles      10
seg  94.0°C  00m30 max
[ '.' insert seg ]
[ ↑ ↓, ↵ to edit ]
[ ← to delete seg ]
    
```

The bottom line may change or it may also flash between two or three different prompts depending upon which top line is highlighted. A prompt line which flashes between three different prompts is shown here.

Indicators



Power: This indicator is lit when there is power to the TC-312



Status: This indicator is lit when the TC-312 is running a program. It is off when the unit is stopped. It will flash and beep slowly when the unit is paused. It will flash after a five second quick sequence of beeps when the unit reaches its final hold temperature.

The Keys

The 'End', 'Finish' or 'Exit' key



The 'End' or 'Finish' key is used to finish editing programs or exit a program. It is also used to exit a sequence of key operations.

The 'Up arrow' key



The 'Up arrow' key is used for scrolling up through the lines on the screen. It is also used to increase certain fields when editing.

The 'Down arrow' key



The 'Down arrow' key is used for scrolling down through the lines on the screen. It is also used to decrease certain fields when editing.

The Decimal Point and Insert key



The 'Decimal Point' key is used when editing numeric fields. It is also used as an 'Insert' key during program editing to insert additional segments and other field sets.

The Delete key



The 'Delete' key is used during program editing to delete segments and loops.

The Pause key



The 'Pause' key is used during program editing to insert a pause after a loop or to insert increment and decrement times and temperatures. It is also used to pause a program when it is running.

The Enter or Accept key



The 'Enter' key is used to enter an operation or edit mode. It is also used to 'Accept' a field or program change.

The Alpha/Numeric keys



The 'Alpha/Numeric' keys scroll round the letters and numbers as shown on the keys. If it is a numeric field then numbers will be inserted; if it is an alpha field then letters will be inserted. Each key will cycle through the letters shown on the key (0 will insert a space) to insert a number, press and hold the appropriate key.

Before switching on

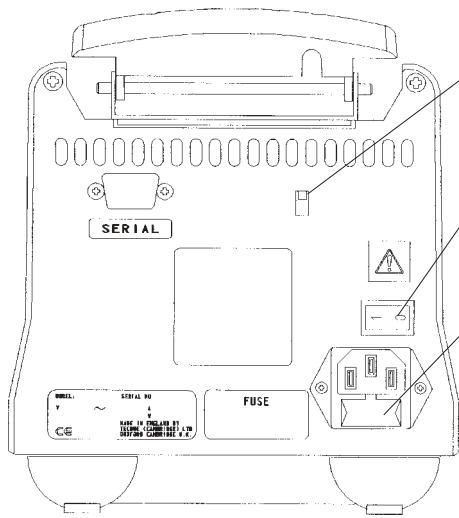

Ensure that the voltage selector switch is set to the appropriate voltage for your supply;

On/Off switch

Ensure that the appropriate fuses are fitted for your supply.

For 230V set the voltage selector switch set to 230V and fit T2.5A fuses.

For 115V set the switch to 115V and fit T4A fuses.

For 100V the switch will be set to 115V T4A fuses will be fitted.

Switching on

```

TC-312
Version          X.XX
Block #         TG 25 x 0.2ml
                TG 20 x 0.5ml
    
```

When you switch on you will first see a screen similar to this one. This screen will appear for a short time then the next screen will automatically appear.

If you need to confirm the block type and software version, you can go into 'Information' from the next screen

Symbols on the Screen



In the prompt line is equivalent to the "End" key



On a program line means the program is locked; it can be copied and then edited but not edited directly.



Up arrow



Down arrow



Enter



Pause



Glossary

Loop

Loop is the name given to the main repeated part of a program containing the 'Segments' to be repeated. Typically a program has only one 'Loop' although for protocols such as Cycle Sequencing, multiple 'Loops' may be required with each 'Loop' being repeated a different number of 'Cycles'

Cycle

Cycle is the number of repetitions of a 'Loop'

Segment

Segment is a user defined program line containing a temperature, a hold time and ramp rate. Typically 3 segments are created within 1 'Loop'.

[Note: Some manufacturers and the 'Template' programs refer to a segment as a 'step'.]

Example Programs

Typical 3-Step PCR

Heated Lid		110
Preheat Lid		off
Pause		off

In denat	94°C	5min
Hot Start		off

- - - - - Loop 1 - - - - -		
Number Cycles		30
seg	94°C	0m30 max
seg	55°C	0m30 max
seg	72°C	0m30 max

Final Extn	72°C	5m
Final hold		10

3-Step PCR with multiple 'Loops'

Heated Lid		110
Preheat Lid		off
Pause		off

In denat	94°C	5min
Hot Start		off

- - - - - Loop 1 - - - - -		
Number Cycles		10
seg	94°C	0m30 max
seg	50°C	0m30 max
seg	72°C	0m30 max

- - - - - Loop 2 - - - - -		
Number Cycles		20
seg	94°C	0m30 max
seg	58°C	0m30 max
seg	72°C	0m30 max

Final Extn	72°C	5m
Final hold		410

Stopping what you are doing



At any time during programming the TC-312 that you are satisfied with the program, you can finish and accept what you have done by first pressing the "End" or "Finish" key.

Prompt Line

```
-- Loop 1 -----
Number cycles      10
seg 94.0°C 00m30  max
[ '.' insert seg ]
[ ↑ ↓, ↵ to edit ]
[ ← to delete seg ]
```

Then follow the instructions on screen. If you are not sure, **wait for the instructions** in the prompt line to scroll back to the first line that you see. Example of three lines is shown.

Accept



To accept a screen, program, etc or to get into 'Edit' mode you usually have to press the "Enter" key.

Some Frequently asked Questions

- Q1 What's the 'pause function' (as far as it concerns the before program operation)?
- A1 Some users prefer to preheat the heated lid before placing the samples into the unit. The pause feature is used to stop the unit after the 4 minute heated lid preheat step. It will also sound an audible alarm indicating that the the machine is ready for the sample tubes or plate to be added. Pressing 'unpause' twice will commence the remaining program.
- Q2 Why do you have to press some keys twice to make the unit do what you want it to do.?
- A2 With many of the program features there is a fail-safe function which asks if you are sure you want to perform a particular action. You then have to press a key a second time.
- Q3 What is the appropriate pressure of the heated lid? If we do it the way it is described in the manual the tubes are stuck on the membrane.
- A3 If the tubes stick to the lid then this could be because there is some grease or dirt on the rubber pad. We recommend that the user occasionally dusts the rubber pad with talcum powder to avoid sticking. It is important not to overtighten the lid *a light contact is sufficient*.
- Q4 What is "Hot start"?
- A4 Hot Start is used to make the machine pause after the initial denaturation at a specific temperature, typically around 70°C. The reason is to allow the addition of TAQ enzyme after the initial 5min denaturation, this prolongs the half-life and activity of the enzyme.
- Q5 What is the incremental function? See pages 30 and 31.
- A5 Incremental timing and temperature are used to increase either the time or temperature incrementally over the 30 cycles.
- Incrementation of time is used with 'Long PCR' which is when large template fragments are to be amplified (27KB lambda, 40KB genomic).
- Decremental temperature is used for protocols such as 'Touchdown PCR' where one starts at a high anneal temperature and gradually decrease the temperature over the 30 cycles, this ensures a highly specific product is amplified.
- Q6 The way you enter a new program is not quite understandable.
- A6 The logic of this manual is as follows:
- a Open programs
 - 1 New programs
 - 2 Templates
 - 3 Existing programs
 - b Edit programs (including adding segments, loops, etc, to a new program)
 - c Run programs
- Once you are doing what the heading says you remain in that function until you get to another heading.
- Q7 It is not always clear the order that you add parts to the program.
- A7 The software will always add a line if you have missed it out. For example if you add a 'segment' and you have not added the 'cycles' the software will add a line "Number of Cycles 1" above the segment. You can then edit this line if you require more than one cycle.
- If you require further assistance please telephone Techne with the unit in front of you and we can go through the programming function.

Notes on transferring protocols from slower machines

The TC-312 heats at over 3.6°C/s and provides the highest levels of temperature uniformity. Many slower machines have historically began the countdown on hold times **before** the set temperature is reached in order to avoid any overshooting in sample temperature. The slower the heating rate the more significant the loss in hold time, i.e. if a 30 second hold time is set at 55°C then perhaps 5 to 10s will be lost in between the start of the time countdown and actually reaching the set temperature. The overall effect of this method of control is that your sample is subjected to an environment with an elevated temperature compared to the target temperature.

The TC-312 provides the user with 'What-you-program-is what-you-get'. Due to the rapid and responsive nature of the Peltier heating system, the time between the timer countdown initiating and actually reaching the set temperature has been reduced to as little as 1s. This ensures that the sample is only subjected to the exact temperature required.

Taking the above into consideration it must therefore be noted that care must be taken when re-optimizing protocols from a slower machine.

Trouble Shooting

1. The optimum anneal temperature may in fact be higher than the set temperature used in the slower machine. Try increasing by 1 or 2°C.
2. The hold time can be reduced once the optimum temperature has been found. Reduce by 5 to 10s.

Programming the TC-312

```

Programs
Information
Configuration
[ ↑ ↓, ↵ to select ]
    
```

When you switch the unit on and the initial screen has disappeared this screen will automatically appear.

For "Configuration" refer to separate administration sheet.



To go into "Programs" from this screen **press "Enter"**.

```

* * New program * * * *
2 STEP TEMPLATE  ]
3 STEP TEMPLATE  ]
[ ↑ ↓, ↵ to select ]
    
```

This screen will appear:

Programming Options

- There are two options available when programming the TC-312.
- 1 Copy one of the Templates;
 - 2 Create a new program from the defaults.

Creating PROGRAMs, Option 1, Using templates

```

2 STEP TEMPLATE
Heated Lid          110°C
Preheat Lid         on
Pause               off
-----
In denat            94.0°C 5m00
Hot Start           off
- - - - Loop 1 - - - -
Number Cycles      30
seg    94.0°C    0m30    max
seg    68.0°C    1m00    max
-----
Final Extn         72°C   5m00
Final hold         10
    
```

```

3 STEP TEMPLATE
Heated Lid          110°C
Preheat Lid         on
Pause               off
-----
In denat            94.0°C 5m00
Hot Start           off
- - - - Loop 1 - - - -
Number Cycles      30
seg    94.0°C    0m30    max
seg    55.0°C    0m30    max
seg    72.0°C    0m30    max
-----
Final Extn         72°C   5m00
Final hold         10
    
```



Use the “Down Arrow” key

to choose an existing ‘Template’ program from the menu, i.e 2 Step Template or 3 Step Template.

```

* * New program * * * *
2 STEP TEMPLATE
3 STEP TEMPLATE
[ ↑ ↓, ↵ to select ]
    
```

The Template is already defined and can easily be copied, modified and saved under a new name.

The program can be used as it is or used as the basis of your new program.



Press the “Enter” key to select it.

Use the “Down arrow” to

```

Run Program
View Program
Copy Program
[ ↑ ↓, ↵ to select ]
    
```

choose ‘COPY PROGRAM’.



Press “Enter”.

```

UNNAMED #
Heated lid          110°C
Preheat lid         on
[ ↑ ↓, ↵ to edit ]
    
```

A new name can then be given to the copied program. See the next page.

This program can now be used as it is. See also the next page.

Alternatively it can be edited and saved using the standard procedures outlined on the next pages.

To give a new program a name



The unit will automatically select a PROGRAM NUMBER.

If you want to give it a name press "Enter".

```

UNNAMED #
Heated lid      110°C
Preheat lid     on
[ ↑ ↓, ↵ to edit ]
  
```

The cursor will move to the position shown and when you have typed in the name it will replace the number title.



Type in the name you wish to give the program.

Remember that the letters will scroll round with successive presses, for example the "2 Key" will give 'A' with one press; 'B' with two presses; 'C' with three presses and '2' with four presses. Five presses will again give 'A'.



When the name is complete, press "Enter".

You now have two more options:

- 1 Save the program and then run it as it is;
- 2 Edit the program, see the instructions on the following pages, then save it and run the program.

To save the program



You can only run a program once you have saved it.

At any time you are satisfied with the way you have set up the program, press "End".

```

-- Loop 1 -----
Number cycles      10
seg  94.0°C  00m30 max
[      SAVE ?      ]
[ ↵ Yes or ▽ NO ]
  
```

The prompt line will flash between 'SAVE?' and 'YES or NO'.

Press "Enter" for 'Yes' to save the changes you have made.

If you press "End", ▽, for 'No' then all the changes you have made will be lost.

For instructions on running a program go to Page 31.



Creating a "new" program, Option 2,

```

UNNAMED #
Heated lid      110°C
Preheat lid     off
Pause          off
- - - - -
In denat       94.0°C  5m00
Hot start      off
- - - - -
Fin extn       72.0°C  5m00
Fin hold       10°C
[ ↑ ↓, ↵ to select ]
    
```

A number of typical values are pre-entered including 'Heated Lid Temp', 'Preheat Lid', 'Initial Denaturation', 'Hotstart', 'Final Extension' and 'Final Hold'. These values can be edited and the additional segments requiring cycling can be added by following the instructions detailed on the following pages.

```

* * New program * * * *
2 STEP TEMPLATE
3 STEP TEMPLATE
[ ↑ ↓, ↵ to select ]
    
```

Create a new program by choosing ** New Program ** from the menu.



Press "Enter".

To add a loop and then edit it



Use the "Down Arrow" key

```

In denat       94.0°C  5m00
Hot start      off
- - - - -
[ ↵ to insert loop ]
    
```

to scroll to the second dotted line it will flash.



Press "Enter" to insert a loop.

```

-- Loop 1 -----
Number cycles  █
seg  94.0°C  00m30  max
[ ↵ edit no. cycles ]
    
```

A new loop will be inserted.

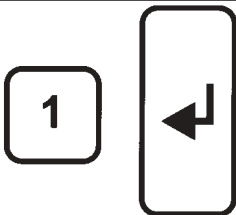

Edit the number of cycles by typing the number required then press "Enter".



```

-- Loop 1 -----
Number cycles      10
seg 94.0°C 00m30  max
[ '.' insert seg ]
[ ↑ ↓, ↵ to edit ]
[ ← to delete seg ]
    
```

Use the "Down Arrow" key to move to 'Seg'.

The 'prompt' line will flash between 'insert seg', 'to edit' and 'to delete seg'.



To edit the segment information press "Enter".

Type in the information you require for each field.

```

-- Loop 1 -----
Number cycles      10
seg 94.0°C 00m30  max
[ ↑ ↓, ↵ to edit ]
    
```

The first field is the temperature to which the segment will go; the second field is the hold time in minutes and seconds; the third field is the ramp rate in °C/sec



Press "Enter" to progress to the next field. Repeat for each field.

When the segment line again flashes you have come out of edit.

If you want to revert to the default values, press 'End'.

To insert additional segments

```

-- Loop 1 -----
Number cycles      10
seg 94.0°C 00m3  max
[ '.' insert seg ]
[ ↑ ↓, ↵ to edit ]
[ ← to delete seg ]
    
```

Highlight 'Number Cycles' to insert a segment before the first one.

Highlight 'seg... ' to insert a segment after an existing one.



Press '.' in both cases to insert a segment.

Repeat the steps above to edit each segment.

To give a new program a name



The unit will automatically select a PROGRAMME NUMBER.

If you want to give it a name press "Enter".

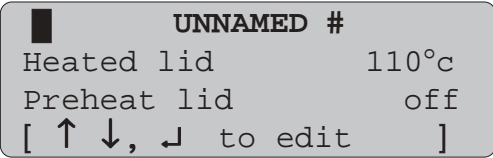

The cursor will move to the position shown and when you have typed in the name it will replace the number title.



Type in the name you wish to give the program.

Remember that the letters will scroll round with successive presses, for example the "2 Key" will give 'A' with one press; 'B' with two presses; 'C' with three presses and '2' with four presses. Five presses will again give 'A'.



When the name is complete, press "Enter".

You now have two more options:

- 1 Save the program and then run it as it is;
- 2 Edit the program, see the instructions on the following pages, then save it and run the program.

To save the program



You can only run a program once you have saved it.

At any time you are satisfied with the way you have set up the program, press "End".

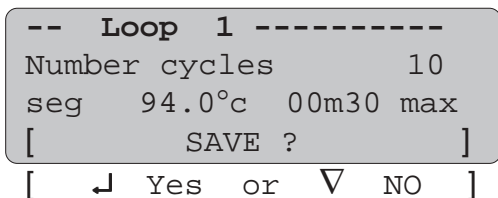

The prompt line will flash between 'SAVE?' and 'YES or NO'.

Press "Enter" for 'Yes' to save the changes you have made.

If you press "End", ∇, for 'No' then all the changes you have made will be lost. For instructions on running a program go to Page 31. This page is a repeat of page 21 for completion of 'Option 2'.



Further programming

The next few pages extend programming from the previous pages

To edit, copy or delete an existing program

```

Programs
Information
Configuration
[ ↑ ↓, ↵ to select ]
    
```

When you switch on or save a program the display will show this screen.

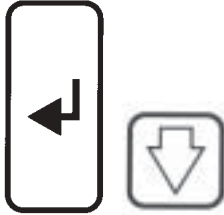

Press "Enter".

Use the "Down arrow" key to

```

Albert
Donna
Fred
[ ↑ ↓, ↵ to select ]
    
```

scroll through to the program you want to edit, copy or delete.

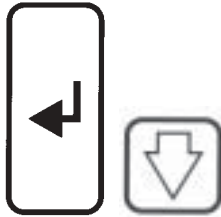

Press "Enter".

Use the "Down arrow" Key to scroll through the options.

```

Donna
Run program
View program
Edit program
Copy program
Delete program
Set password
[ ↑ ↓, ↵ to select ]
    
```

The full set of options are shown here.

These are shown three lines and a prompt line at a time

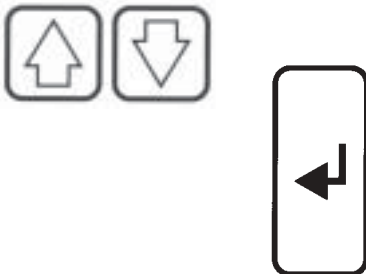

Use the "Down arrow" and/or the "Up arrow" key to select the option you require.

Press the "Enter" key to select the option.

Edit a selected program

```

Donna
Heated lid      110°C
Preheat lid      off
[ ↑ ↓, ↵ to edit ]
    
```

If you select 'Edit program', for example, a screen similar to this one will appear.

You can now edit the program as described previously

To Copy a Selected Program

```

UNNAMED #
Heated lid      110°C
Preheat lid    off
[ ↑ ↓, ↵ to edit ]
    
```

If you select 'Copy program' a screen similar to this one will appear and the unit will automatically give the program the next number.

Type in a new name and you will be able to edit the program as previously described.

To Delete a Selected Program

```

Donna
[ DELETE PROGRAM ? ]
[ ↵ Yes or ▽ NO ]
    
```

If you select 'Delete program' a screen similar to this one will appear

Press "Enter" to delete the program or "END" to return to the earlier screen.

To Set a Password for a Selected Program

```

Donna
New passwd █
[ ↵ to accept ]
[ ▽ to exit ]
    
```

If you want to give a program a password so that other users cannot edit your program, select 'Set password'. A screen similar to this one will appear.

Type in the password you wish to give it and press "Enter". The program list will then display the key symbol next to the name

Other users will be able to copy/view your program.

To delete a segment

```

-- Loop 1 -----
Number cycles    10
seg 94.0°C 00m30 max
[ '.' insert seg ]
[ ↑ ↓, ↵ to edit ]
[ ← to delete seg ]
    
```

Use the up or down arrow keys to highlight the segment you wish to delete.



Press "Delete".

```

-- Loop 1 -----
Number cycles    10
seg 94.0°C 00m30 max
[ DEL SEGMENT ? ]
[ ↵ YES OR ▽ NO ]
    
```

The prompt line will flash between 'DEL SEGMENT?' and 'Yes or No'.

Press "Enter" to delete the segment.



Press "End" to return to editing the segment.



To add a loop before an existing one



Use the arrow keys to highlight the loop number.

```
-- Loop 1 -----
Number cycles      10
seg  94.0°C  00m30 max
[ ↓ to insert loop ]
[ ← to delete loop ]
```



Press "Enter".

A new loop will be added before the existing loop. The loop numbers will be adjusted as appropriate. Once you have added the loop you can edit it as above.

To add a loop at the end



Use the arrow keys to highlight the dotted line.

```
In denat  92.0°C  5m00
Hot start                off
-----
[ ↓ to insert loop ]
```



Press "Enter".

A new loop will be added and will have the next higher number. Once you have added the loop you can edit it as above.

To delete a loop



Use the up or down arrow keys to highlight the loop you wish to delete.

```
-- Loop 1 -----
Number cycles      10
seg  94.0°C  00m30 max
[ ↓ to insert loop ]
[ ← to delete loop ]
```



Press "Delete".

```
-- Loop 1 -----
Number cycles      10
seg  94.0°C  00m30 max
[   DEL LOOP ?   ]
[ ↓ YES OR ∇ NO ]
```

The prompt line will flash between 'DEL LOOP?' and 'Yes or No'.



Press "Enter" to delete the loop.

To insert a 'pause' into a program

```
seg 94.0°C 00m30 max
-- Loop 2 -----
Number cycles
seg 94.0°C 00m30 max
[ '.' insert seg ]
[ ↑ ↓, ↵ to edit ]
```

The default pause after the 'Preheat Lid' command is only active in that position and can only be switched 'on' or 'off'.

To insert a pause after an existing loop, first insert a loop as above. The loop is inserted in the edit number of cycles mode.



Press "Pause".

```
seg 94.0°C 00m30 max
-- Loop 2 -----
Number cycles      1
seg 94.0°C 00m30 max
[ '.' insert seg ]
[ ↑ ↓, ↵ to edit ]
```

The prompt line will flash between 'CHANGE TO PAUSE?' and 'YES or NO'.



Press "Enter".

```
-- Loop 2 -----
Pause
-----
[ ↵ to insert loop ]
[ ← to delete loop ]
```

And the loop number will be highlighted with 'Pause' as the only line.

To Program increment or decrement temperature or time.

Under normal circumstances, the Hold Temperature of all segments is constant. However, it is possible to automatically increment or decrement the temperature of a specified segment of a programme.

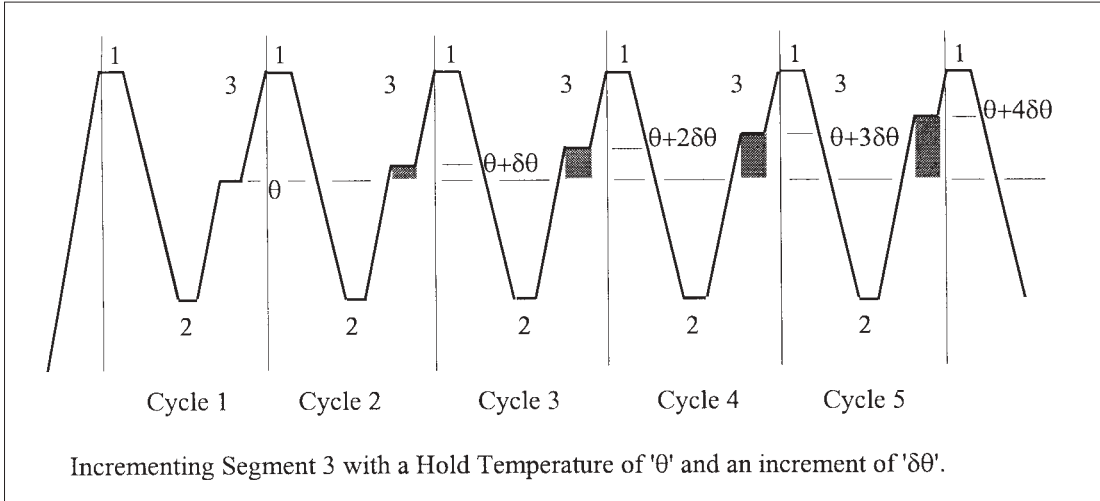

The Hold Temperature of the incremented/decremented segment is the defined Hold Temperature plus the summation of the increments/decrements. The first cycle is never incremented/decremented, only subsequent Cycles. If you select a decrement, the Hold Temperature is prevented from falling below 4°C. If you select an increment, the Hold Temperature is prevented from rising above 99°C.

Similarly, under normal circumstances, the Hold Time of all segments is constant. However, it is possible to automatically increment or decrement the duration of a specified segment of a programme.

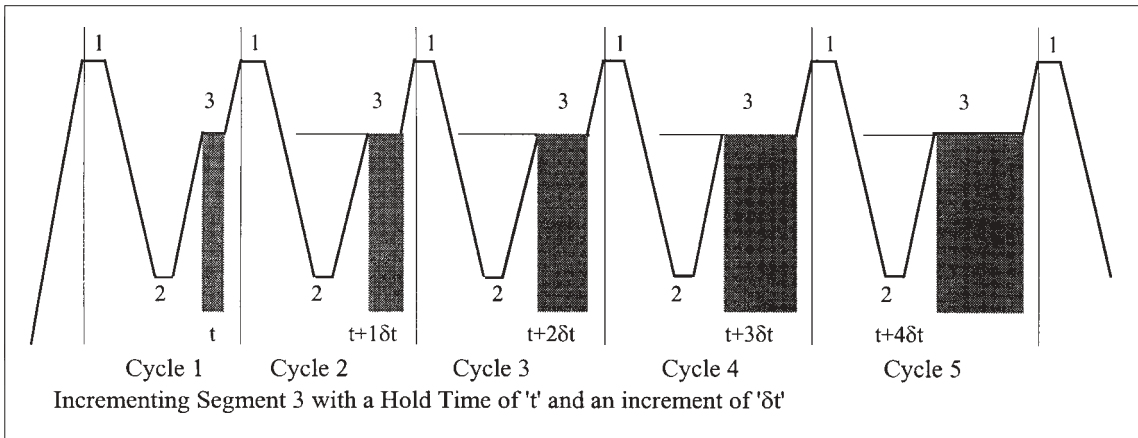

The Hold Time of the incremented/decremented segment is the defined Hold Time plus the summation of the increments/decrements. The first cycle is never incremented/decremented, only subsequent Cycles. If you select a decrement, the Hold Time is prevented from falling below one second.



Use the “Up arrow” or “Down arrow” key

```

-- Loop 1 -----
Number cycles      10
seg 94.0°C 00m30 max
[ '.' insert seg ]
[ ↑ ↓, ↵ to edit ]
[ ← to delete seg ]
    
```

to move onto the segment where you want to have increment temperature or time.



Press “Enter” and you go into edit mode.



Press “Pause”

```

-- Loop 1 -----
Number cycles      10
seg 94.0°C 00m30 max
[ CHANGE SEG ? ]
[ ↵ YES OR ▾ NO ]
    
```

The prompt line will change to flash between ‘Change Seg?’ and ‘Yes or No’.



Press “Enter”.

```

-- Loop 1 -----
Number cycles      10
seg 94.0°C 00m30 max
[ ↑ ↓, ↵ to edit ]
    
```

The cursor will move into the edit mode.



Press the “Up arrow” key.

```

Number cycles      10
fst 92.0°C 5m00 max
lst 92.0°C 5m00 max
[ ↑ ↓, ↵ to edit ]
    
```

The segment will change to ‘fst’, meaning “first”, and the software will insert another line after it entitled ‘lst’, meaning “last”.



Press “Enter” and you will be in edit mode.

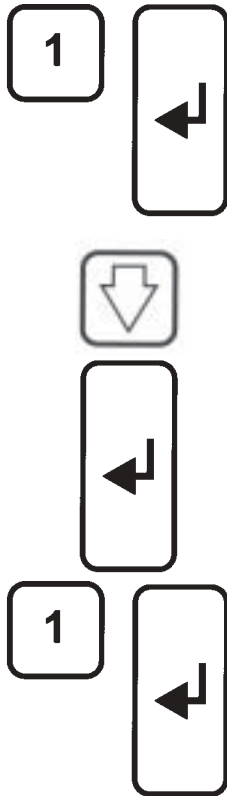

```
Number cycles      22
fst  50.0°C  3m00  max
lst  72.0°C  7m00  max
[ ↑ ↓, ↵ to edit ]
```

Use the “Alpha/numeric” keys to change the values in the line with the title ‘fst’ to the first temperatures and times you want.

Press “Enter” for each field you change.

You will come out of Edit Mode when you get to the end of the line.

Use the “Down Arrow” key to move onto the ‘lst’ line.

Press “Enter” and you will be in edit mode.

Use the “Alpha/numeric” keys to change the values the line with the title ‘lst’ to the final temperatures and times you want.

Press “Enter” for each field you change.

You will come out of Edit Mode when you get to the end of the line

When you run the program it will automatically equi-change from the first time and/or temperature to the last over the number of cycles. For example: if the first temperature is 50°C and the last temperature is 72°C over 22 cycles then the temperature will increase 1°C each cycle. Similarly the time would increase from 3 minutes to 7 minutes in 10.9 second increments for the example shown.

To save the program



```
-- Loop 1 -----
Number cycles      10
seg  94.0°C  00m30  max
[      SAVE ?      ]
[ ↵ Yes or ▽ NO ]
```



You can only run a program once you have saved it. At any time you are satisfied with the way you have set up the program, **press "End"**.

The prompt line will flash between 'SAVE?' and 'YES or NO'.

Press “Enter” for ‘Yes’ to save the changes you have made. If you press “End” for ‘No’ then all the changes you have made will be lost. For instructions on running a program go to Page 32.

To run a program

Programs

Information
 Configuration
 [↑ ↓, ↵ to select]

When you switch on or save a program the screen will come to this screen.

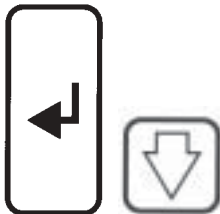

Press "Enter".
Use the "Down arrow" key to
 scroll through to the program you want to run.

Albert
Donna
 Fred
 [↑ ↓, ↵ to select]

For example "Donna"



Press "Enter".

Donna
Run program
 View program
 [RUN PROGRAM ?]
 [↵ Yes or ▾ NO]

Choose 'Run Program'.



Press "Enter".

Donna
 [RUN PROGRAM ?]
 [↵ Yes or ▾ NO]

A screen similar to this one will appear.



Press "Enter" again and the unit will start the program.

Cycle 1/1 → 6m30
 Sample 94.0°C
 Hold @ 94.0 0m14
 [|| to pause]
 [▾ to stop]
 [↵ information]

The first screen will look something like this.

Manual Pause

```
Cycle 1/1      → 6m30
Sample         94.0°C
Hold @ 94.0    0m14
[  ||  to pause ]
[  ▽  to stop  ]
[  ↵  information ]
```

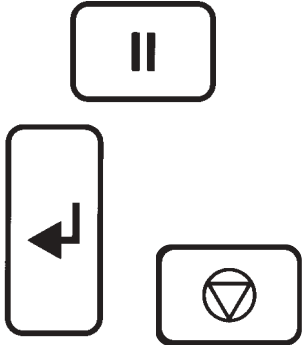

To pause a program while it is running,

press "Pause".

To Confirm that you want the program to stop

press "Enter".

The program will not actually pause until you press "Enter".

If you have pressed the "Pause" key by mistake and you want the program to continue,

press "End".

Manual Stop

```
Cycle 1/1      → 6m30
Sample         94.0°C
Hold @ 94.0    0m14
[  ||  to pause ]
[  ▽  to stop  ]
[  ↵  information ]
```

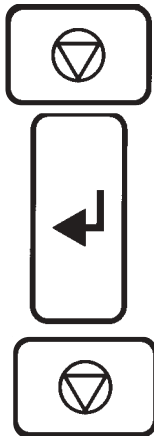

To stop a program while it is running,

press "End".

To confirm that you want to stop the program

press "Enter".

The program will not actually stop until you press "Enter".

If you have mistakenly pressed the "End" key and you want the program to continue,

press "End" again.

```
Stopped
[  ↵  to run  ]
```

When a program is stopped the screen will change to:

Program Information

```
Donna
Heated lid      on
Status          Ramping
[  ↑ ↓, ↵  to edit ]
```

If you press the "Enter" key while a program is running you will get information about the status of the unit. An example is shown here.

Additional information

Brief fault finding notes and a list of replacement parts are given in this section.

NOTE THAT THIS EQUIPMENT SHOULD ONLY BE DISMANTLED BY PROPERLY TRAINED PERSONNEL. **REMOVING THE OUTER COVER EXPOSES POTENTIALLY LETHAL MAINS VOLTAGES.** THERE ARE NO USER SERVICEABLE PARTS WITHIN THIS EQUIPMENT.

Fault Finding

Should you have any problems with your TC-312 which cannot be easily remedied, you should contact your supplier and return the unit if necessary. Please include details of the fault observed and remember to return the unit in its original packing. Techne accept no responsibility for damage to units which are not properly packed for shipping: if in doubt, contact your supplier, giving the full serial number of the unit and software version number (shown when the unit is first switched on).

Fuses

If neither the power light nor display on the front panel are lit, one of the two fuses may have blown. Check that there is no external cause, such as a faulty plug or lead. Check both fuses and replace the faulty fuse with a new one of the correct value. (Fuse values are given on the label next to the power inlet.) Note that fuses should only be replaced by a qualified electrician.

The holder for the two fuses is built into the mains input socket. First remove the power cable, then gently prise the fuse drawer open with a flat-bladed screwdriver or similar tool.

Each fuse can be removed by using the screwdriver as a lever.

Exchange the faulty fuse in the fuse holder for a working fuse of the correct value. Finally, replace the fuse drawer in the fuse compartment and push the drawer shut.

Fuses which blow repeatedly indicate a serious fault and you should return the unit to your supplier for repair.

The Heated Lid Over temperature cutout

Your Heated Lid is fitted with an independent circuit to protect it from overheating. In the unlikely event of an Over-temperature problem with the lid, the unit is fitted with a thermal fuse which remove power to the heater plate should the maximum temperature be exceeded.

Insulation Testing

This equipment is fitted with RFI suppression circuitry. Any check of the electrical insulation by means of high voltage dielectric testing (for example as in BS EN 61010-1) must be carried out using only a DC voltage.

This unit contains semiconductor components which may be damaged by electric field effects.

Running the TC-312 from a PC

The TC-312 can be run from a PC using Techne's Gensoft software. This is available from the Web-site at www.techneuk.co.uk, you will need 'Winzip' (which is available free of charge on www.winzip.com) to unzip the files. A copy of the instructions for using Gensoft is included on a separate leaflet.

You will need a "9-pin female to female, null modem, RS232, fully screened' cable.

Other Information on the Web-Site

Log onto the web-site www.techneuk.co.uk. Enter the 'Support area' and you will find the 'Techne Cyclor Update' area there. Follow the instructions on the site to install the programs.

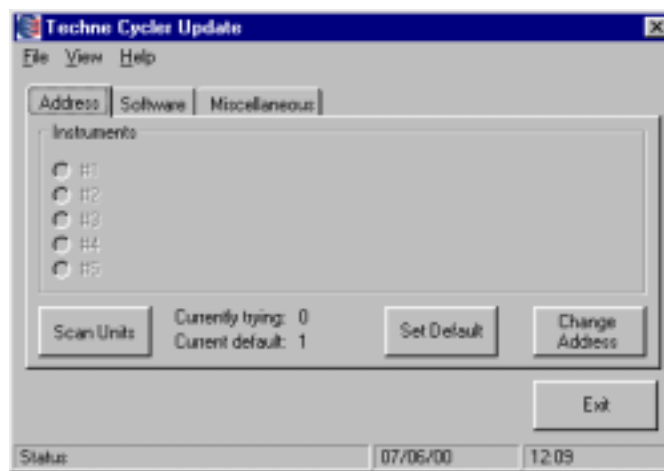

From this screen you can set the address of the TC-312 if it is daisy-chained but this can also be done through 'Administration', see the separate leaflet.

Upgrading the software in your TC-312

You will be able to get the latest software from the web-site as well. Since we are continually striving to improve our units we would be grateful should you consider any improvements you would value. We may not always be able to incorporate them in this software in which case we would record them for future consideration.

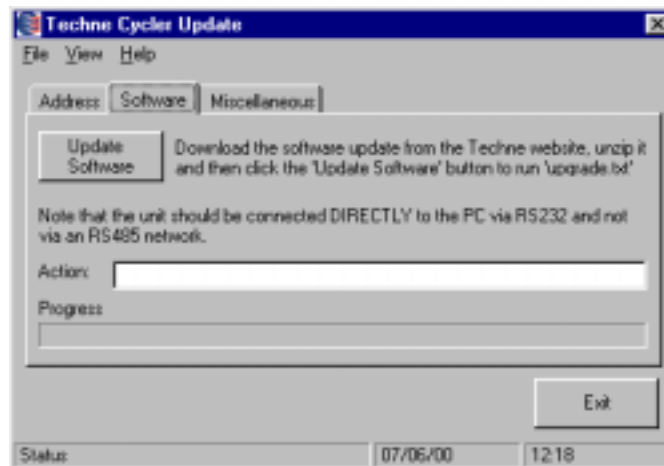

Connect your TC-312 to your computer using an RS232 lead. Click on 'Software' as shown above. Click on 'Update Software' and follow the instructions to download the new software into your TC-312.

Miscellaneous

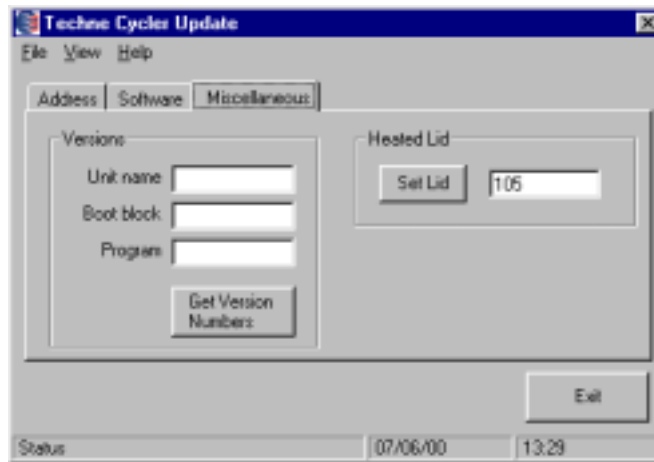

There are two things under 'Miscellaneous'.

- 1 One is that you can retrieve information about your unit, your block and your program.
- 2 The other is that you can set the temperature of the heated lid though this can be done through your program as well. This function is designed for the TC-312PC unit.

Connecting one unit to the computer using an RS 232 cable

If you are driving one unit only you will need FGEN232 which includes; a cable, the software on disc and an instruction sheet.

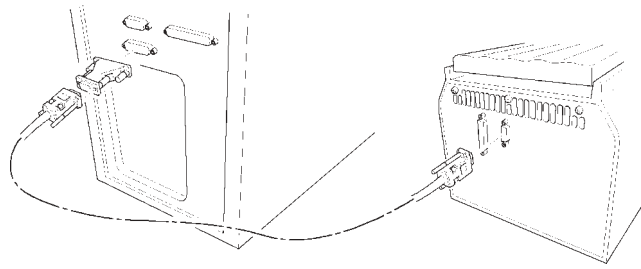

Connecting several units to the computer using the daisy chain cables

If you are driving two or more units then you will need FGEN485D, a 230V UK power pack set, or FGEN485E, a 230V European power pack set, or FGEN485P, a 120/100V USA power pack set. A power pack set includes: the connection to a computer which also converts to RS485; a power pack; the necessary cables; a termination box; and the software on disc with an instruction sheet. You will also need one or more of the following:

- FAGENTWO** A two unit set which includes: Two connectors for the Cyclers and a cable to connect them.
- FGENFIVE** A five unit set which includes: Five connectors for the Cyclers and four cables to connect them.
- FAGENTEN** A ten unit set which includes: Ten connectors for the Cyclers and nine cables to connect them.
- FGENONE** A one unit set for extending the daisy chain which includes: One connector for the Cycler and one cable for connecting it to the daisy chain.

Notice from the diagram that the cable connections to the Cyclers are alternately bottom to top on the connector.

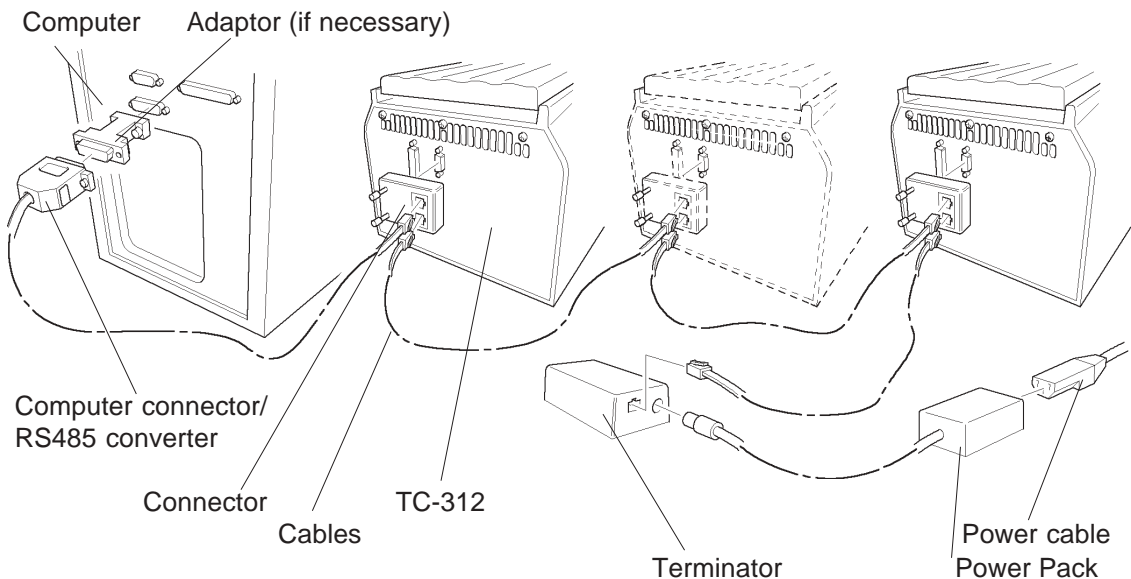

Interchangeable Blocks

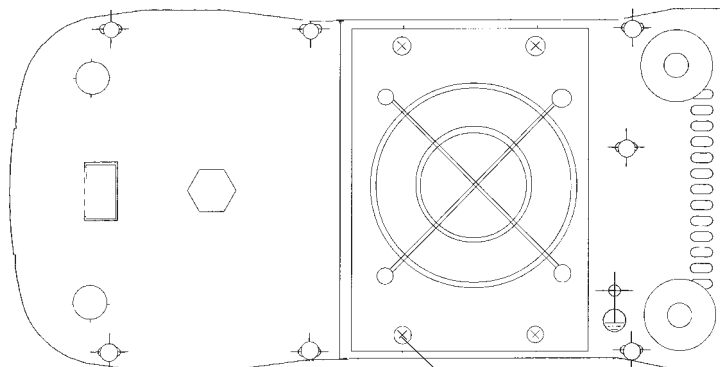

Underside of the TC-312

Four screws which hold the Block/Fan Assembly

The blocks can be removed and exchanged for another of the same sort or of a different sort. The software will register the change and setup the unit for the new block.

Remove the four screws beneath the unit and drop the block/fan assembly down. Unplug the assembly from the wiring and remove the assembly from the unit. Refitting the block/fan assembly is the reverse procedure, be careful of the wires as you refit the block.

Accessories

The following accessories can be obtained from Techne or your Techne dealer:

Item No	Description	Quantity
FBLTG02	0.2ml Tube Block	
FBLTG05	0.5ml Tube Block	
FTUB02TW	0.2ml micro tubes	Pack of 1000
FTUB05TW	0.5ml Micro tubes thin wall	Pack of 1000

Replacement parts

The following replacement parts can be obtained from Techne or your Techne dealer:

Item N°	Description	Quantity required
FCABRTUK	Mains cable and plug, 230V UK	1
FCABRTEU	Mains cable and Schuko plug, 230V Europe	1
FCABRTUS	Mains cable and 3-pin plug, 100V/120V US type	1
6501231	Fuse T2.5A (230V units)	2
6500129	Fuse T4A, (120/100V units)	2