

VGA 77 — High productivity vapor generation

Technical Overview

VGA 77 for 200 Series AA

Introduction

The Agilent fully automated modular VGA 77 Vapor Generation Accessory is ideal for rapid trace level determinations of mercury (using the proven cold vapor technique) and other hydride-forming elements at parts-per-billion ($\mu\text{g/L}$) concentrations. The VGA 77 offers:

- The convenience of flame AA determinations
- Unmatched precision at ppb levels
- Sets new standards for ease-of-use, flexibility and automation



Figure 1. The VGA 77 Vapor Generation Accessory provides fast, accurate determination of Hg and hydride forming elements at ppb levels simply and automatically.

The modular construction of the VGA 77 eliminates cross-contamination, which can be introduced by the conflicting chemistries required for different elements, such as arsenic and mercury. Residual reagents from determinations of one element can degrade the analytical signal of another. The entire plumbing assembly is integrated into a separate module, which can be simply exchanged when switching between elements. This reduces change-over times and eliminates cross-contamination.

The continuous flow VGA 77 offers the convenience of flame AA operation, while delivering exceptional precision with total flexibility and automation. Benefits of the VGA 77 include:

- High sensitivity
- Precisions of 1-2 % RSD at ppb levels, achieved using integration of the steady state signal for a few seconds
- High sample throughput. Results are achieved in less than 1 minute allowing determination of up to 70 samples/hour
- Simple operation. The integral pump provides continuous flow conditions with automatic reagent addition
- Enhanced stability. The continuous flow conditions ensure a stable baseline and eliminate varying blank levels
- Low sample consumption – < 8 mL per element during analysis
- Modular construction to reduce set-up time and eliminate cross-contamination — simply exchange modules when switching between elements with conflicting chemistries
- Enhance productivity by coupling the VGA 77 with the SPS Sample Preparation System. This automates hydride and mercury vapor determinations with automated sampling, reagent addition, calibration and sample analysis

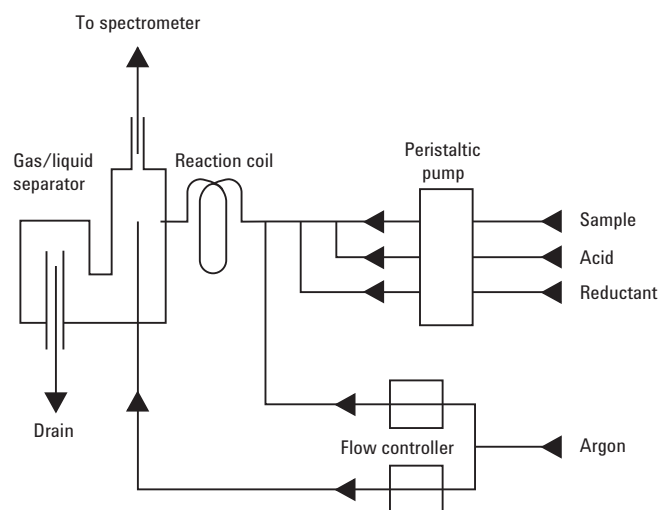

Figure 2. Simply aspirate your sample and read. The VGA 77 automatically mixes acid and reductant with the sample. The resulting vapor flows into the atomization cell for measurement.

Advantages of continuous flow vapor generation

The continuous flow VGA 77 offers the following advantages over competitive techniques, such as Flow Injection:

- Unequaled performance with better sensitivity than discrete injection techniques
- Enhanced precision — the VGA 77 produces a steady state signal, which can be measured using conventional integration. Flow injection produces transient signals, requiring time-consuming multiple injections for precise results
- Greater productivity — samples only need to be aspirated once to obtain precise results from multiple replicates. Flow injection produces transient signals, requiring separate injections for each replicate reading. Each replicate consumes several milliliters of sample to ensure the injection loop is filled. This reduces sample throughput and increases sample consumption
- Simple and automatic operation — each sample is automatically combined with a continuous flow of acid and reagents

Table 1. Typical performance

Element	Char. µg/L	Detection Limit µg/L	Detection Limit with ETC 60 µg/L
Hg	0.3#	0.05	N/A (cold vapor)
As	0.2	0.09*	0.02* (0.0013**)
Se	0.2*	0.1*	0.04* (0.003**)
Sb	0.15	0.06*	-
Bi	0.2	0.07*	0.05
Sn	0.3	0.15*	0.15
Te	0.15	0.15	0.1

with flow through cell

* using Varian high intensity UltrAA lamps

** when instrument has an R4332 PM tube

Unattended hydride analyses

For increased sensitivity and reduced detection limits, combine the VGA 77 with the ETC 60 Electrothermal Temperature Controller. Utilizing electrical heating of the atomization cell, the ETC 60 adds the economy of flameless atomization. Flame heating of the atomization cell is eliminated, enabling atomization at lower temperatures. This enhances sensitivity and enables safe, unattended, flameless hydride determinations. This also facilitates hydride determinations using the Zeeman instrument module.

The combination of the ETC 60 with the VGA 77 offers these unique benefits:

- Flameless atomization of the hydride-forming elements
- Reduced running costs, as flame gases are eliminated
- Safe, unattended hydride determinations for improved productivity
- Reduces baseline noise by eliminating flame flicker
- Increases sensitivity by up to 30 %. Atomization temperatures can be programmed for each element (typically < 1000 °C). This increases the atom residence time in the optical path, ensuring enhanced sensitivity
- Lower detection limits (sub ppb) are achieved, resulting from the improved signal-to-noise performance

For more information

For more information on our products and services, visit our Web site at www.agilent.com/chem/

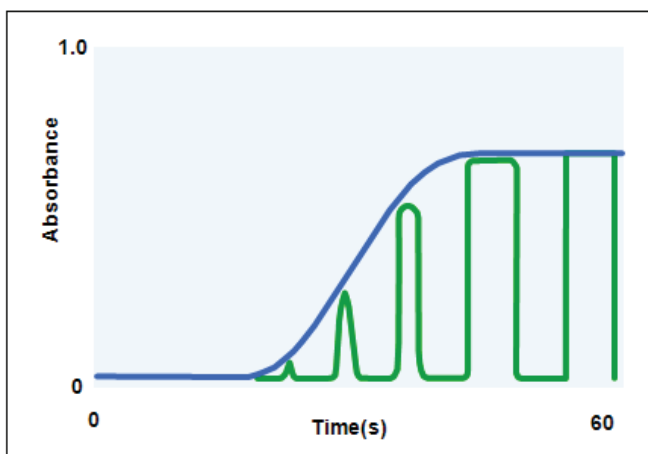

Figure 3. The continuous flow design of the VGA 77 offers superior sensitivity compared with discrete injection techniques like Flow Injection. Discrete injections can only approach the sensitivity of the VGA 77 by injecting large sample volumes. This effectively provides continuous flow conditions.

www.agilent.com/chem

Agilent shall not be liable for errors contained herein or for incidental or consequential damages in connection with the furnishing, performance or use of this material.

Information, descriptions, and specifications in this publication are subject to change without notice.

© Agilent Technologies, Inc. 2010

Published in USA, April 23, 2013
Publication number: 5990-6710EN

The Measure of Confidence

